

Wall Mounted Work Station WS Line

Assembly Guide



Poste de travail mural Ligne WS

Guide d'assemblage

- All required hardware is included excepted for wall anchoring (see note ⚠).
- Please check the contents with your packing slip.
- Read instructions carefully.
- Save this document for future reference.
- Two people are required for the assembly.

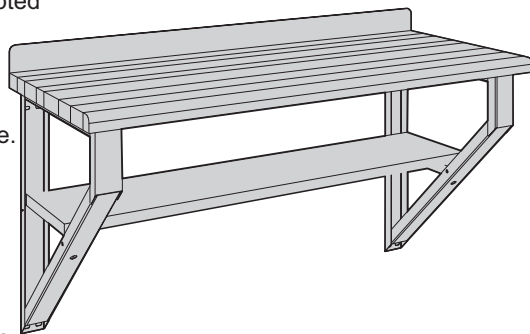

- Toute la quincaillerie requise est incluse sauf pour l'ancrage au mur (voir note ⚠).
- Veuillez vérifier le contenu avec votre feuille de livraison.
- Lisez attentivement les instructions.
- Conservez ces instructions pour référence future.
- Deux personnes sont requises pour l'assemblage.



The client is responsible for installing the product in a secure manner, to a wall capable of supporting this application, and for determining and using the appropriate anchoring hardware.



Le client a la responsabilité d'installer le produit sécuritairement, à un mur capable de recevoir cette application, et de déterminer et d'utiliser la quincaillerie d'ancrage appropriée.

Hardware

Quincaillerie

• Some hardware illustrated is only supplied with optional components.

• Certaines quincailleries illustrées sont seulement fournies avec les composantes optionnelle.

5/16-18 bolt
Boulon 5/16-18
3L120202

1/4-20 bolts
Boulons 1/4-20
3A1818L2

Tapping screw
Vis taraudeuse
3D1618L2

Tapping screw
Vis taraudeuse
3D5326T2

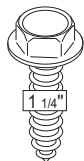
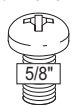
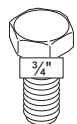

Tools Required

Outils requis

Cut-resistant gloves
Gants anti-coupure

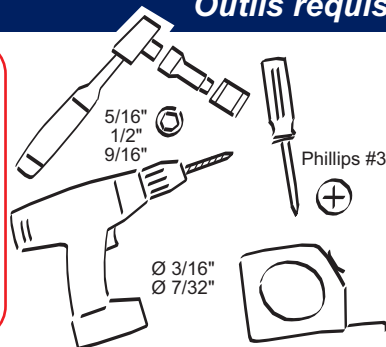

Steel Top - Set up

Dessus en acier - Préparation

- 1 If the WS11 steel top reinforcer is required...
Si le renfort de dessus en acier WS11 est requis...

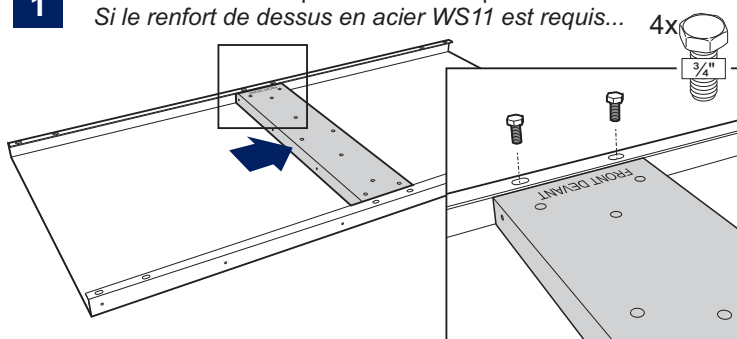

- 2 If required, insert the wood filler WS75.
Si requise, insérez la doublure de bois WS75 dans le dessus.

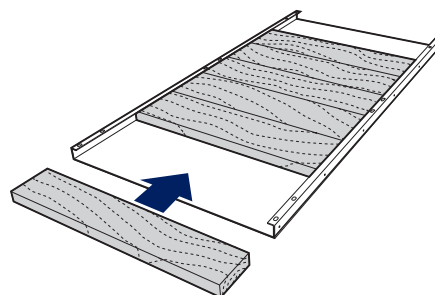

- 3 **For WS12 stainless steel top.**
Remove finishing sides of the steel cross bars at this step, if you want to install side stops later in this guide.

Pour les dessus en acier inoxydable WS12.

Retirer les côtés de finition des traverses en acier à cette étape, si vous souhaitez installer des rebords de côté, plus loin dans ce guide.

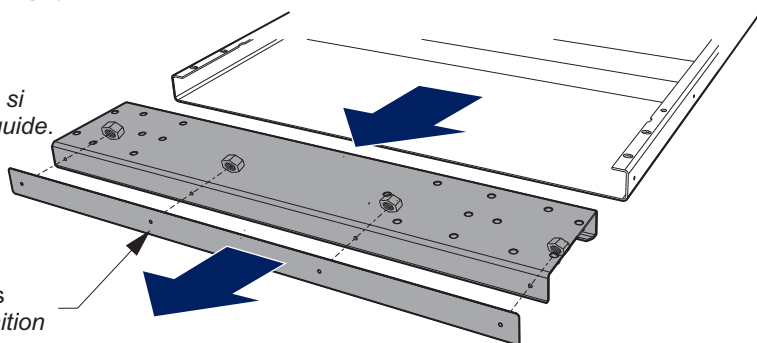

Remove finishing sides
Retirez les côtés de finition

4 Finally, insert and fasten the steel cross bars at each end of the top.
 Enfin, insérez et fixez les traverses en acier aux extrémités du dessus.

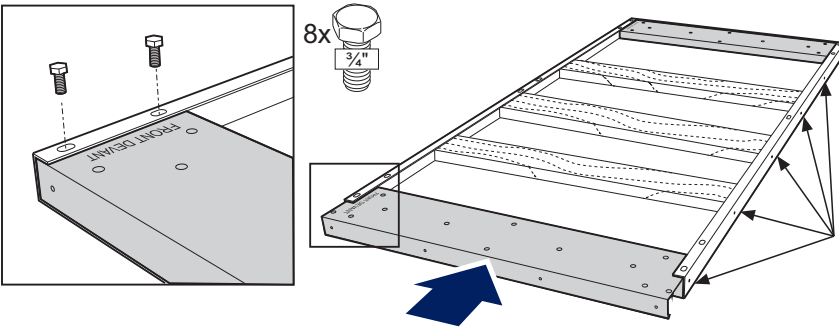

!
 WS11 steel top reinforcer & steel cross bars have "FRONT DEVANT" markings.
 The **front** edge of the **top** has no holes. The **rear** edge of the **top** has many holes to allow future installation of back stops WS18/83/93/98.
 Les renforts de dessus en acier WS11 & les traverses en acier ont une inscription "FRONT DEVANT". Le **devant** du **dessus** en acier ne comporte pas de trou. **L'arrière** du dessus est muni de trous pour l'assemblage de rebords de dessus WS18/83/93/98.

Holes for **back** stop WS18/83/93/98.
 Trous pour rebords **arrière** de dessus WS18/83/93/98.

Top and legs - assembly

Dessus et pattes - assemblage

Wood or Plastic Laminated Top
 Dessus en bois ou en stratifié

Steel Top
 Dessus d'acier

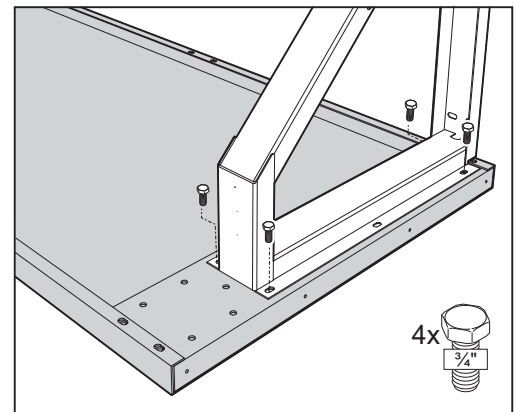
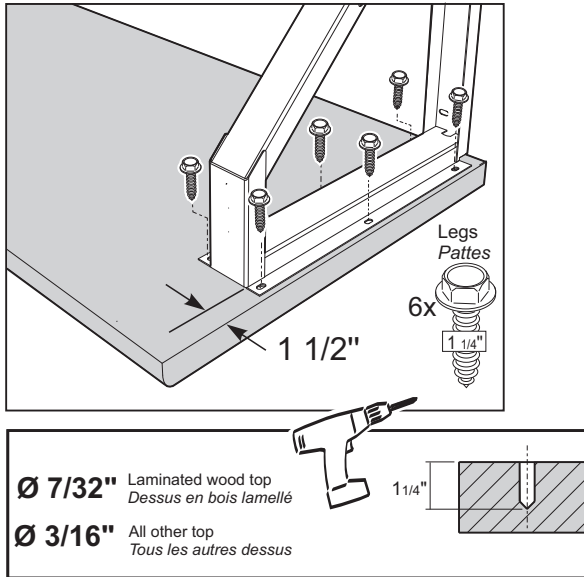

Ø 7/32" Laminated wood top
 Dessus en bois lamellé
 Ø 3/16" All other top
 Tous les autres dessus

If Used without Top Accessories

Si utilisé seul sans accessoires de dessus

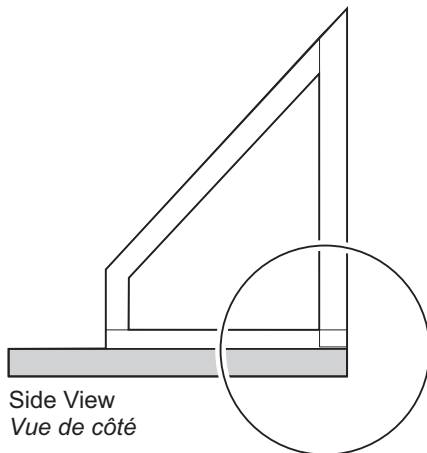

Side View
 Vue de côté

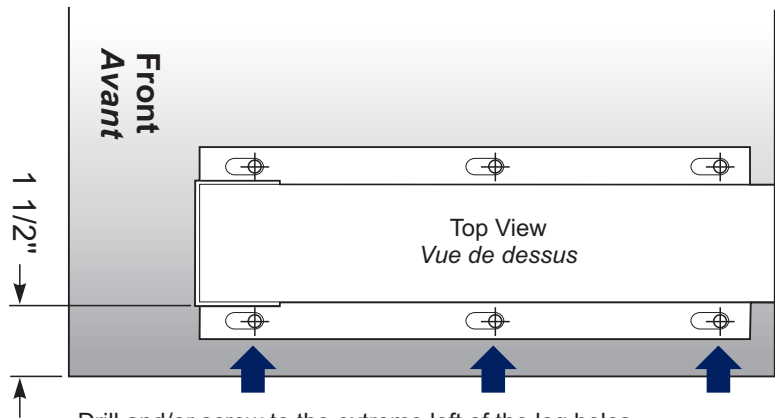

Drill and/or screw to the extreme left of the leg holes.
 Percer et/ou visser à l'extrémité gauche des trous de la patte.

If Used with Top Accessories

Si utilisé avec accessoires de dessus

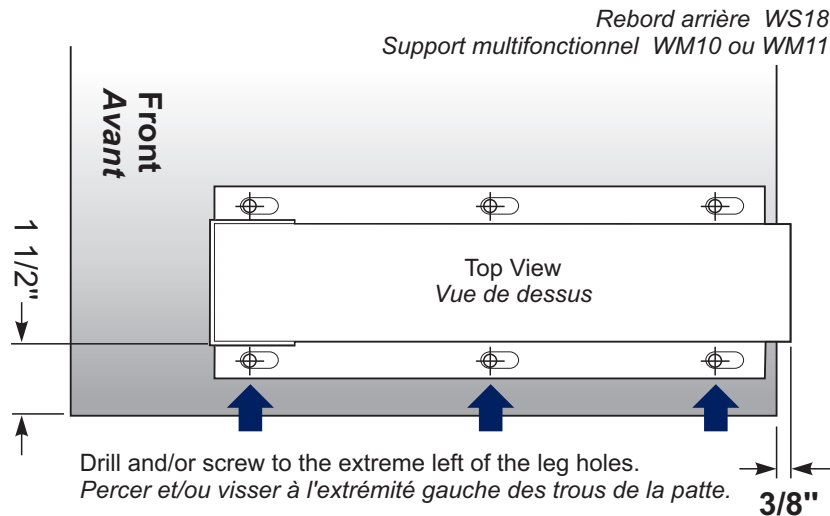
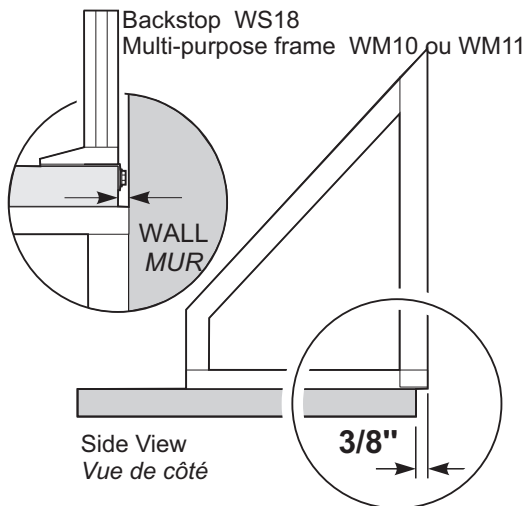

Leg Cross Bar WS24

Traverse WS24

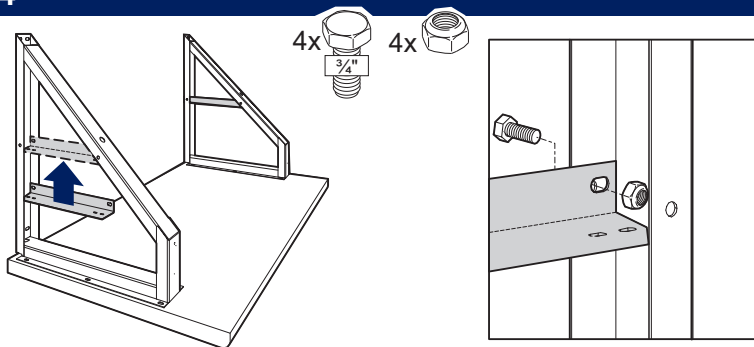

Steel Shelf WS50

Tablette en acier WS50

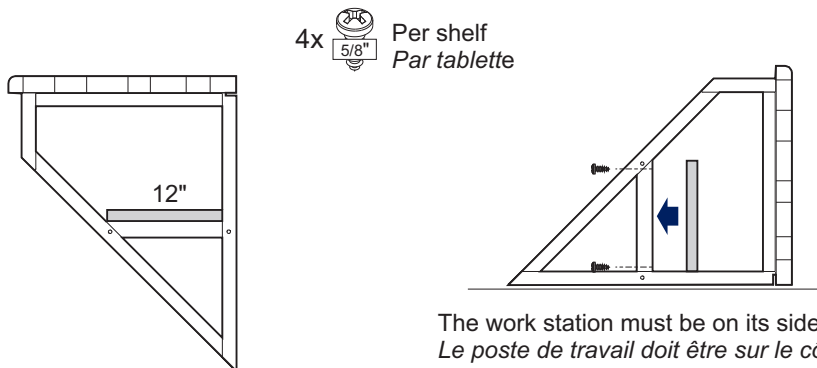

Back or Side Stop WS18

Rebord de dessus WS18

- Align the bottom of the stop with the underside of the top.
- Use tapping screws to secure it in place.

- Alignez le bas du rebord avec le dessous du dessus.
- Utilisez des vis taraudeuses pour le fixer.

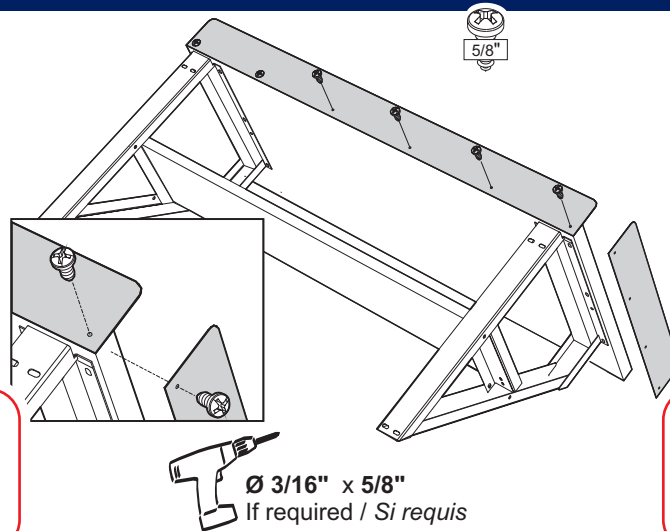

STAINLESS STEEL drilling:

See stainless steel drilling guide R1T (7D00201T) included with the product.

Perçage de l'ACIER INOXYDABLE :

Voir guide de perçage de l'acier inoxydable R1T (7D00201T) inclus avec le produit.

Multi-Purpose Frame

Support multifonctionnel



SEE GUIDE NO W20
VOIR GUIDE NO W20

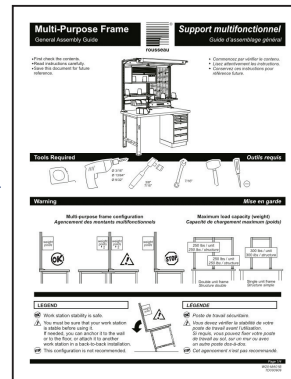
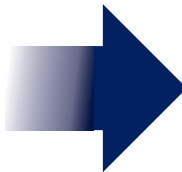

That's it!
To assemble other components, consult the respective assembly guide.

C'est fait!
Pour l'assemblage des autres composantes, consultez leurs guides respectifs.